

Rheology Characterization of Polymer Drilling Foams using a Novel Apparatus

Zhu Chen¹, Ramadan M. Ahmed¹, Stefan Z. Miska¹, Nicholas E. Takach¹, Mengjiao Yu¹ and Mark B. Pickell¹
Arild Saasen²

1 - Department of Petroleum Engineering, The University of Tulsa, 600 South College Av.,
Tulsa, OK, USA

2 - Statoil, N-4035, Stavanger, Norway

ABSTRACT

This experimental study focuses on the rheological characterization of polymer-based drilling foams using a Foam Generator/Viscometer. This apparatus generates and replenishes foam to a flow-through Couette viscometer. Experimental results show that besides foam quality, liquid phase rheology plays a great role in foam rheology and wall roughness also affects rheology measurements.

INTRODUCTION

Foams have been used in a number of petroleum industry applications such as oil well drilling, enhanced oil recovery, oil well fracturing, etc. Among these applications, the use of foams as drilling fluids has experienced a large growth in underbalanced drilling operations due to its good cuttings carrying capacity and Equivalent Circulation Density (ECD) management capability. Nevertheless, foam is a compressible, dynamically unstable non-Newtonian fluid with complex structures. Many variables such as foam quality (in-situ gas volume fraction), liquid phase rheology, foam texture, surfactant type and concentration, and wall slip affect its flow behavior.

In practical foam drilling operations, both aqueous and polymer-based foams have been used. As long as aqueous foam can satisfy all the desired properties for a given underbalanced drilling operation, polymers

are not used due to economic concerns. Nevertheless, adding polymers to the liquid phase affects the rheology and stability of subsequent foams. Polymer-based foams can be especially beneficial for underbalanced drilling operations in situations such as: i) drilling unconsolidated formations because polymer-based foam has an excellent capacity to stabilize this type of formation; ii) drilling water-sensitive shale formations that tend to slough badly; iii) drilling deeper wells where foam stability can be a potential problem; and iv) drilling large-diameter holes that required a large amount of compressed air.

Previous drilling foam studies¹⁻⁵ were mainly focused on rheology and cuttings transport of aqueous foams. The effect of polymer on foam rheology was not included in the investigations. Rheology of foam can be modified by adding viscosifying polymers to the liquid phase. However, little research has been conducted to evaluate the degree to which the bulk properties of drilling foams are enhanced by polymers. It is apparent that there is a need for polymer foam rheological investigation to improve the knowledge of foam rheology and hydraulics.

Foam rheology can be measured using either pipe or rotational viscometers. Pipe viscometers used in foam rheology study include single-pass pipe viscometer and re-circulating pipe viscometer. In general, the re-circulating pipe viscometer can be used to

investigate time-dependent flow behavior while a single-pass pipe viscometer can only be used to study foam rheology at steady state conditions. Rotational viscometers used in foam rheology study include Couette-type viscometers, parallel disk and cone and plate viscometers. Couette-type viscometers have been widely used for rheology measurement of incompressible drilling fluids. However, foam rheology studies with rotational viscometers are very limited because foam is an unstable fluid. When foam is loaded to a rotational viscometer, the liquid phase drains out rapidly, leading to incorrect rheological measurements.

This experimental study focuses on the rheological characterization of polymer-based drilling foams using a Foam Generator and Viscometer Apparatus and Process⁶. This instrument is capable of controlling the following variables independently: i) foam quality; ii) pressure; iii) temperature; iv) quantity of surfactants and other additives; v) bubble size; and vi) surface roughness. The apparatus generates and replenishes foam with controllable properties to a flow-through Couette viscometer (Thermo Haake RS-300). The flow-through capacity enables foam rheology to be measured under dynamic conditions so that the influences of foam drainage and bubble coalescence on rheology measurements can be minimized. To investigate the effect of roughness on foam rheology measurement, in addition to the original smooth cup-rotor assembly, two sets of cups and rotors of the Couette viscometer were roughened without changing the original cup-rotor gap width. Wall slip is believed to originate due to the formation of a thin liquid film that lubricates flow at the wall. By roughening the wetted surfaces of the viscometer, the effect of wall slip on rheology measurements can be minimized. The grooves that were machined into the cup and rotor surfaces have a tendency to contain the liquid film and minimize the wall slip.

Experiments were conducted at 25°C (77°F) and 1.72×10^5 Pa (25 psig) using three cup-rotor assemblies that have different

surface roughnesses. Foams used in this study were composed of air, water, Hydroxyl-ethyl-cellulose polymer (Weatherford KLEAN-VISH HEC) with different concentrations (0.25% and 0.5% v/v) and 1% v/v surfactant (Weatherford KLEAN-FOAM). Foam qualities were varied from 70% to 90%.

In this study, the rheological properties of polymer-based foam have been evaluated and results show that besides foam quality, polymers affect the apparent viscosity of foam significantly. Experimental results also indicate that foam rheology measurements are affected by the surface roughness of the cup-rotor assemblies.

LITERATURE REVIEW

A literature review reveals that polymers have been widely used in foam fracturing operations. Rheological studies⁷⁻¹¹ on fracturing foams have been conducted with different polymers (Hydroxypropyl guar, Carboxy-methyl-hydroxyl-propyl guar and Xanthan Gum). In contrast, previous rheological studies on drilling foams are mainly focused on aqueous foams. Limited rheological studies¹²⁻¹³ on polymer-based drilling foams were conducted; i.e., studies were conducted using limited types of polymers and polymer concentrations were fixed. Most of the published data on polymer-based fracturing foams were collected with low quality foams and high polymer (guar) concentrations. Hence, correlations developed for fracturing foam rheology may not be applicable for drilling foams. An independent study is needed to investigate the effect of polymers on the rheology of polymer-based drilling foams.

Prior to the development of the Foam Generator/Viscometer Apparatus used in this study, Wenzel et al.¹⁴ and Marsden et al.¹⁵ studied foam rheology using modified concentric cylinder viscometers. In their studies, vanes and fins were used to modify the viscometers and minimize slippage. Recently, foam rheology was studied using a flow-through viscometer (Thermo Haake RS-300) by Washington¹⁶. Pickell¹⁷ also studied

transient rheological properties of aqueous foams using the Foam Generator/Viscometer, and this study suggested that the mixing energy applied during foam generation plays an important role. Foam apparent viscosity increased with the amount of energy added but becomes asymptotic at some value.

EXPERIMENT

Test Setup

The Foam Generator/Viscometer Apparatus (Fig. 1) consists of: i) a rotational viscometer; ii) a foam generator; iii) a CCD camera together with a microscope; iv) a liquid injection pump; v) compressed air and liquid bottles; and vi) an electronic balance. The foam generator is made of a cylinder with piston and mixer. The piston is movable and separates the cylinder into two chambers (mixing chamber and pneumatic chamber). A caliper is installed to measure displacement of the piston. The dome-shaped design of the piston assists re-circulation of the fluids back down the sidewalls of the mixing chamber. A variable speed motor turns the mixer (propeller) over a wide range of rotary speeds. A view-port is placed in the flow line between the generator and the viscometer. This view-port enables observation of the foam and/or optical measurements of foam properties such as bubble size. The injection pump is used to meter and pump proper amounts of liquid into the mixing chamber. A gas source together with pressure regulators, gauges and control valves is used to introduce gas at a selected pressure into the mixing chamber and the pneumatic chamber. The pneumatic chamber maintains constant pressure in the mixing chamber when foam flows from the mixing chamber to the viscometer. Bubble size is controlled by using different: i) impellers; ii) rotary speeds; and iii) mixing times in the generator. For this study, a 3-inch propeller was used and the rotating speed was set at 1750 rpm for all tests. A predetermined mixing period was also used for all tests. This guaranteed that

foams were equilibrated before rheology measurements.

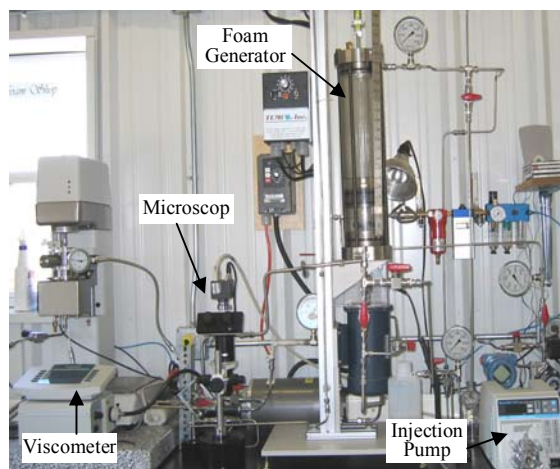

Fig. 1 Foam Generator/ Viscometer

Test Procedure

Figure 2 shows a schematic of the Foam Generator/Viscometer Apparatus. The test process begins by mixing water, polymer and surfactant in desired ratios and quantities in the liquid bottle. From there, measured quantities of the liquid phase are pumped into the mixing chamber using a liquid injection pump. The cell is then isolated from the pump by

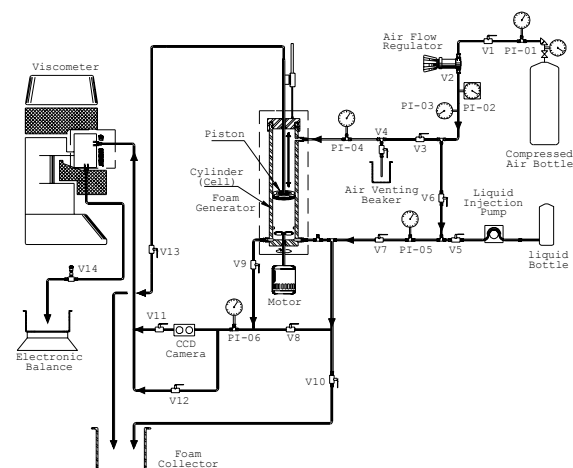

Fig. 2 Schematics of the Foam Generator/ Viscometer

closing the liquid injection valve (V5) and air is supplied from a compressed air bottle. Temperature inside the mixing cell is

measured by a thermostat connected to a thermocouple. The temperature and pressure inside the mixing chamber are constantly monitored. Once injection of the gas and liquid phases is completed, valves (V3 and V6) are manipulated to apply gas to the top of the piston. The piston maintains constant pressure on the foam. Next, a propeller inside the foam generator is rotated at a chosen speed and period of time to generate foam. Propeller design, rotation speed and mixing time determine the amount of shear energy applied and the resulting bubble size. Once foam with the desired properties is generated, it is allowed to flow through the adjoining viscometer. A needle valve (V14), which is located downstream of the viscometer, enables control of the flow rate through the viscometer. An appropriate foam flow rate is necessary to minimize drainage and axial flow effect. The foam mass flow rate through the viscometer is determined by measuring total mass of liquid phase using an electronic balance. The electronic balance is connected to a computer and the total mass is recorded at a rate of six samples per minute. The needle valve is continuously-adjusted during a test so that the desired mass flow rate is maintained during the rheology measurements. An essential feature of the Generator/Viscometer Apparatus is that it minimizes the effects of axial flow while maintaining the integrity of the foam. Foam rheology is measured with the RS-300 Viscometer, and the measurements are controlled and recorded with a computer.

The detailed test procedure includes the following steps: 1) Pumping a measured volume of liquid phase (surfactant and aqueous polymer solution) into the mixing cell; 2) Filling the cell with gas at a given pressure; 3) Charging the flow line between the generator and viscometer with the same gas pressure; 4) Activating the propeller and letting it turn until the foam equilibrates; 5) Flowing equilibrated foam through the viscometer while maintaining constant pressure by applying gas pressure on the pneumatic chamber. In this way, foam quality

is kept constant during the test; 6) Adjusting the needle valve to keep the mass flow rate in the appropriate range while measuring average liquid phase mass flow rate using the electronic balance; 7) Measuring the foam rheology when steady flow condition is established; 8) Taking pictures of the foam through the view-port using a CCD camera coupled to a microscope. Photographs are taken after the propeller has been turned off.

Introduction of Roughened Viscometer Rotors and Cups

When foam rheology is measured with this Thermo Haake RS-300 viscometer, the smooth inner cylinder rotates and deforms the bulk foam, resulting in bubble movement that displaces bubbles away from the surface boundaries. The enrichment of the boundary near the smooth wall with liquid phase results in a lubrication effect. This liquid layer reduces the shearing of the bulk foam, which causes reduction in the torque measurements. It was reported^{6,16-20} that wall slip effect can be minimized by adding wall roughness to the contact surfaces of a viscometer. Two sets of roughened cup-rotor assemblies (cup-rotor assembly #1 and cup-rotor assembly #2) were manufactured. These assemblies are geometrically identical to the original smooth cup-rotor assembly. A roughness measuring instrument (Surftest 401) was used to quantify the roughness of the rotors and cups. The results of surface roughness measurements are presented in Table 2. The roughness of cup-rotor assembly #2 is greater than that of assembly #1.

Viscometer Calibration Tests

In order to correct for end effects and bearing drag, a series of calibration tests using four standard calibration oils (range of viscosity is from 50 to 500 cP) were conducted to calibrate the smooth cup-rotor assembly. The end effects tend to increase measured torque due to shearing of the fluid between the space above and below the rotor inside the cup (Fig.3). Altogether thirteen different standard viscosity tests (Table 3) were carried out and

calibration curves for different shear rates (1000, 600, 400, 300, 200, 100, 50, 30, 20 and 10 s^{-1}) were prepared. Measured and theoretically calculated torques were compared for each shear rate and a calibration curve was prepared to obtain the true torque based on the measured torque. A sample calibration curve obtained at 400 s^{-1} shear rate is presented in Fig. 4. Similar curves were prepared to correct the measured torque at different shear rates.

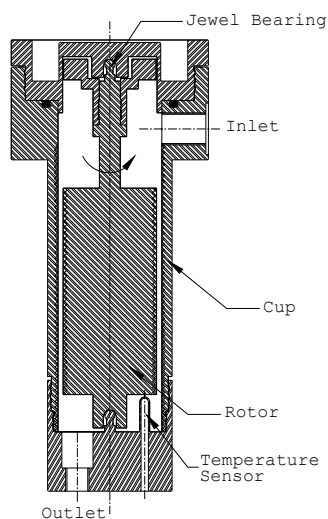

Fig. 3 Rotor-cup assembly of RS-300

For the other two roughened cup-rotor assemblies, calibration tests were also performed to determine the effect of roughness and rotor weight. Two calibration tests were conducted. Results show that all the cup-rotor assemblies are geometrically identical and have the same friction drag²⁰. Therefore, it is reasonable to assume that any torque measurement differences resulting from different cup-rotor assembly are due to wall slip.

Foam Flow Rate Through The Viscometer

To correctly measure foam rheology with this unique viscometer, it is important to allow enough flow through the viscometer to minimize the effects of foam drainage and axial flow on rheology measurements. This means the flow rate should not be too high or

too low, both of which will result in inaccurate viscometer readings. The appropriate foam flow rate through the viscometer was determined based on: i) foam flow rate sensitivity experiments, and ii) theoretical analysis. By approximating the annular gap between the rotor and cup with a narrow rectangular slot, and assuming maximum allowable nominal Newtonian axial wall shear rate of 3 s^{-1} (the minimum nominal rotational shear rate for rheology measurement was 10 s^{-1}), the maximum volumetric foam flow rate was determined to be 15 mL/min . This corresponds to a mass flow rate of $15 \cdot (1-\Gamma) \text{ g/min}$. Detailed analysis of this can be found in previous works^{17,18,20}.

Figure 5 shows a sample data (80% quality, 0.25% polymer foam measured with roughened cup-rotor assembly #2) of the total mass of foam flowing through the viscometer versus time. Two curves, which represent the theoretical and measured total mass flows, are plotted on the same set of axes. The slopes of the curves represent the mass flow rate of foam flowing through the viscometer. The balance is tared before foam flows through the viscometer. Then the needle valve is slightly opened and foam is allowed to flow through the viscometer. It was found that at the very beginning the two curves are not parallel because steady flow condition was not established. Foam rheology measurement with the viscometer starts when the two curves become approximately parallel by adjusting the needle valve position. For this particular test, the actual foam mass flow rate was maintained at approximately 3 g/min (i.e. 15 mL/min).

Test Matrix

A test matrix for the rheology experiments is presented in Table 1. Test temperature and pressure were maintained at 25°C and 25 psig . HEC polymer concentration varied from 0.25% to 0.5%. Three foam qualities (70%, 80% and 90%) were tested. Surfactant concentration was 1% by volume. Besides the original smooth cup-rotor assembly, the two

sets of cup-rotor assemblies (Table 2) with different wall roughnesses were used to investigate the effect of wall slip on foam rheology measurements.

TEST RESULTS AND DISCUSSIONS

Base Fluid Rheology

Two concentrations (0.25% and 0.5% v/v) of HEC polymer fluids were prepared, and then the rheology of the liquid phase was measured with a rotational viscometer (Chan-35). Power-Law rheological parameters were obtained for the two polymer fluids, which are shown in Table 4. The apparent viscosities at shear rate of 511 s^{-1} are 4.1 cP and 7.5 cP, respectively. It can be seen that with an increase in polymer concentration, the fluid consistency index, K , increases, while the fluid behavior index, n , decreases slightly.

Foam Rheology Measurements

Polymer-based foam rheology was measured using both smooth and roughened cup-rotor assemblies. Measured shear stress readings were corrected using calibration curves for each shear rate. Figures 6 and 7 show rheologies of 70%, 80% and 90% quality foams (0.25% and 0.5% polymer concentration, respectively) using the smooth cup-rotor assembly. The foams behave like shear thinning fluids and measured shear stresses increase with foam quality. This means foam apparent viscosity increases with foam quality. Similarly, with the increase of polymer concentration from 0.25% to 0.5%, measured shear stresses increase. This means foam apparent viscosity increases with polymer concentration. A Power-Law rheological model was used to fit the measured data.

Measurements obtained using smooth and roughened cup-rotor assemblies can be used to examine wall slip phenomena and provide improved rheological measurements. Foam rheology measurements obtained with the roughened cup-rotor assembly #1 are presented in Figs. 8 and 9. These plots show

that at a given shear rate, the shear stresses measured with the roughened cup-rotor assemblies are higher than those measured with the smooth assembly. This can be explained by the wall slip since the cup-rotor assemblies differ only in their surface roughnesses. Experiments were also performed using a more roughened assembly (assembly #2). Figures 10 and 11 show flow curves obtained using cup-rotor assembly #2. Again, results show that at a given shear rate, the shear stresses measured with the roughened cup-rotor assemblies are higher than those measured with the smooth assembly.

For low foam quality (70%), it seems that the measured shear stress with cup-rotor assembly #2 is the highest. This means that the more roughened cup-rotor assembly is effective in minimizing the wall slip at low foam qualities. Cup-rotor assembly #2 has wider and deeper grooves, which make it possible to contain more liquid in the grooves. Nonetheless, the differences between the measured stresses are not significant for low quality foams.

Careful examination of flow curves for 80% and 90% quality foams indicates that the shear stresses measured using cup-rotor assembly #1 are higher than those obtained using assembly #2. This is possibly because of the differences in the liquid slip layer thickness. For higher quality foams (80% and 90%), the slip layer is relatively very thin. Even the shallow grooves of cup-rotor assembly #1 are sufficient to enclose the thin liquid films. The groove width of the cup-rotor assembly #1 is only $254 \mu\text{m}$ (0.01 inch), which is much smaller than the groove width of assembly #2 ($635 \mu\text{m}$ or 0.025 inch). As a result, assembly #1 has more protrusions per contact area than assembly #2. The greater the number of protrusions, the more effectively they can immobilize foams on the surfaces and thus reduce wall slip.

Flow curves of foams with different qualities and polymer concentrations that were measured with different cup-rotor assemblies were further processed. All flow

curves were fitted with Power-Law rheological models. Figures 12 and 13 present the flow consistency index, K , and flow behavior index, n , values. It can be seen from the plots that:

- i. for foams with the same polymer concentration but measured with different cup-rotor assemblies, although differences in foam rheological parameters K and n are observed, these values are still scattered around a single curve;
- ii. as polymer concentration changes from 0.25% to 0.5%, K and n values change dramatically, which means that polymer concentrations play a more pronounced role in rheology than wall slip;
- iii. as foam quality changes, significant changes in K and n values are observed and these variations are also more pronounced than wall slip effect;
- iv. for a given polymer concentration, the consistency index increases as the foam quality increases while n decreases as foam quality increases.

Results indicate that for low quality foams (70-80%), the flow behavior index, n , is sensitive to polymer concentration and foam quality. However, for high quality foams (80-90%), n is less sensitive to polymer concentration and foam quality.

Results of this study show that surface roughness reduces wall slip and improves polymer-based foam rheology measurements. The measured shear stress difference using different cup-rotor assemblies is mostly within 30%. However, as foam quality changes from 70% to 90%, the measured shear stress difference can be more than 100%. Also, to analyze polymer effect on foam rheology, we compared the present results with a previous work on aqueous foam rheology^{18,20}. It is found that as polymer concentration changes from 0 to 0.5%, the measured shear stress increases significantly.

Based on the foam rheology measurements obtained from different cup-rotor assemblies, it can be concluded that wall slip does affect foam rheology measurements. However, foam quality and liquid phase rheology are more important in determining the bulk foam rheology.

Following this study, a comparison of foam rheology measurements using Couette-type viscometers with measurements using pipe viscometers is underway. Experiments involving chemical formulations containing other polymers are also in progress, and measurements involving a greater range of surface roughness values will follow. Since wall slip is a complex phenomenon, more work is needed for better understanding of near-wall flow conditions.

CONCLUDING REMARKS

From the results of the foam viscometer measurements, a series of conclusions can be drawn. These include:

1. Foam rheology measured with smooth and roughened cup-rotor assemblies indicates that wall slip effect does exist;
2. When foam rheology is measured with the smooth cup-rotor assembly, lower K values and higher n values are obtained;
3. By using the roughened cup-rotor assemblies, wall slip can be suppressed; thus, better foam rheology measurement can be obtained with Couette-type viscometers that have roughened cup-rotor assemblies;
4. Besides foam quality, foam rheology is affected by the liquid phase rheology. The higher the concentration of viscosifying polymer, the higher the apparent viscosity of foam;
5. It is possible to increase the foam apparent viscosity either by increasing foam quality, or by adding polymers in the liquid phase. This offers more choices in controlling foam rheology during foam drilling operations.

ACKNOWLEDGEMENTS

Authors would like to thank all JIP members of the TUDRP/ACTS Project at the University of Tulsa for sponsoring this work, special thanks to Weatherford International Ltd. for providing surfactant and polymers for this study.

REFERENCES

1. Lourenco, A., (2002), "Study of Foam Flow under Simulated Downhole Conditions," M.S. Thesis, the University of Tulsa.
2. Okpobiri G.A., and Ikoku C.U., (1983), "Experimental Determination of Friction Factors for Mist and Foam Drilling and Well Cleanout Operations," *J. of Energy Resources Technology*, **105**, 542-553.
3. Ozbayoglu, M.E., Kuru, E., Miska, S.Z., and Takach, N.E., (2000), "A Comparative Study of Hydraulic Models for Foam Drilling," SPE/PS-CIM 65489.
4. Martins, A.L., Lourenço, A., de Sa, C., (2000), "Foam Properties Requirements for Proper Hole Cleaning While Drilling Horizontal Wells in Underbalanced Conditions," SPE 64382.
5. Mitchell, B.J., (1971), "Test Data Fill Theory Gap on Using Foam as a Drilling Fluid," *Oil and Gas J.*, **6**, 96-100.
6. Reed, T.D., Pickell, M.B. and Volk, L.J., (2004), "Foam Generator and Viscometer Apparatus and Process," U.S. Patent No. 6807849B1.
7. Reidenbach, V.G., Harris, P.C., Lee, Y.N. and Lord, D.L., (1986), "Rheological Study of Foam Fracturing Fluids Using Nitrogen and Carbon Dioxide," *SPEPE*, **1**, 31-41.
8. Harris, P. C. and Reidenbach, V.G, (1987), "High-Temperature Rheological Study of Foam Fracturing Fluids," SPE 13177.
9. Sani, A.M., Shah, S.N. and Baldwin, L. (2001), "Experimental Investigation of Xanthan Foam Rheology," SPE 67263.
10. Khade, S.D. and Shah S.N., (2003), "New Rheological Correlations for Guar Foam Fluids," SPE 80895.
11. Watkins, E.K., Wendorff, C.L., and Ainley, B.R., (1983), "A New Crosslinked Foamed Fracturing Fluid," SPE 12027.
12. Herzhaft, B., (2001), "Correlation between Transient Shear Experiments and Structure Evolution of Aqueous Foams," *J. of Colloid and Interface Science*, **247**, 412-423.
13. Kakadjian, S., Herzhaft, B. and Neau, L., (2003), "HP/HT Rheology of Aqueous Compressible Fluids for Underbalanced Drilling Using a Recirculating Rheometer," SPE 80207.
14. Wenzel, H.G., Brungraber R.J and Stelson, T.E., (1970), "The Viscosity of High Expansion Foams," *J. of Materials*, **5**, 396-411.
15. Marsden, S.S. and Khan, S.A., (1966), "The Flow of Foam through Short Porous Media and Apparent Viscosity Measurement," *SPE J.*, **6**, 17-25.
16. Washington, A., (2004), "A Preliminary Study of the Rheology of Foam using a Rotational Viscometer," M.S. Thesis, The University of Tulsa.
17. Pickell, M.B., (2004), "Preliminary Studies of Aqueous Foam for Transient Rheological and Texture Properties Using a Flow-through Couette Viscometer," M.S. Thesis, The University of Tulsa.
18. Miska, S.Z., Reed, T.D., Kuru, E., Takach, N.E., Ashenayi, K., Ahmed, R.M., Yu, M., Pickell, M.B., Volk, L., and Volk, M. et al., (2004), "Advanced Cuttings Transport Study," Final Technical Report, Contract No. DE-FG26-99BC15178, U.S. DOE.
19. Ahmed, R.M., Kuru, E. and Saasen, A., (2003), "Critical Review of Drilling Foam Rheology," *Annual Transactions of the Nordic Rheology Society*, **11**, 63-72.
20. Chen, Z., Ahmed, R.M., Miska, S.Z., Takach, N.E., Yu, M. Pickell, M.B. and Hallman, J.H., (2005), "Rheology of Aqueous Drilling Foam Using a Flow-through Rotational Viscometer," SPE 93431.

APPENDIX

Table 1 Test matrix for foam rheology experiments

	Test Set #1	Test Set #2	Test Set #3
Measurement Assembly	Smooth Assembly	Less Roughened Assembly #1	More Roughened Assembly #2
Foam Formulation	Air + water + surfactant(1% v/v Weatherford KLEAN-FOAM)+ polymer(Weatherford KLEAN-VISH)		
Polymer concentration	0, 0.25%, 0.5%	0, 0.25%, 0.5%	0, 0.25%, 0.5%
Foam Quality	70%, 80%, 90%	70%, 80%, 90%	70%, 80%, 90%
T (°C)	25	25	25
P (psig)	25	25	25

Table 2 Surface roughnesses of cup-rotor assemblies

		Average Roughness [μm]	Standard Deviation of Roughness [μm]
Smooth Cup-Rotor Assembly	Cup	3.1	3.7
	Rotor	2.0	2.4
Less Roughened Cup-Rotor Assembly #1	Cup	13.0	15.6
	Rotor	38.0	45.5
More Roughened Cup-Rotor Assembly #2	Cup	21.0	25.6
	Rotor	44.0	50.0

Table 3 Viscosity standards used for calibration

Nominal Viscosity (cP)	True Viscosity (cP)	Temperature (°C)
50	52.98	20.0
	43.31	30.0
	29.98	50.0
	21.58	70.0
100	105.4	20.0
	71.14	40.0
	206.7	20.0
200	170.32	29.6
	139.3	40.0
	116.7	50.0
	78.01	75.0
500	520.0	20.0
	349.5	40.0

Table 4 Rheology of polymer fluids by Chan 35 viscometer

Formulation	Reading						Power Law Model
	θ (600)	θ (300)	θ (200)	θ (100)	θ (6)	θ (3)	
0.25% Liquid HEC Polymer Fluid	8	4.1	3.2	1.6	0.2	0.1	$\tau = 0.0143 \gamma^{0.806}$
0.5% Liquid HEC Polymer Fluid	13.5	7.5	5	3	0.3	0.2	$\tau = 0.0255 \gamma^{0.799}$

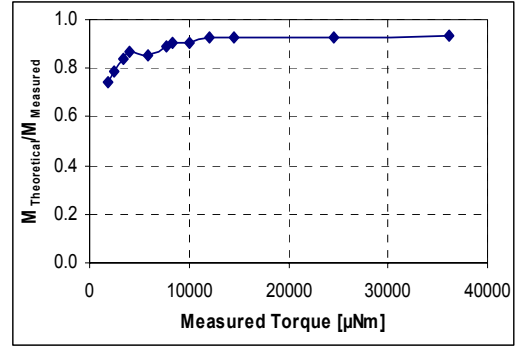

Fig. 4 Viscometer calibration curve obtained at $\gamma=400 \text{ s}^{-1}$

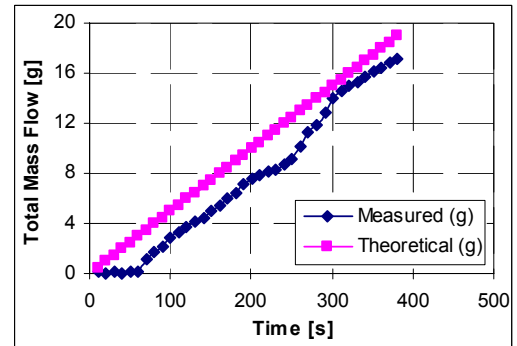

Fig. 5 Total mass flow through the viscometer versus time for an 80% quality 0.25% polymer foam

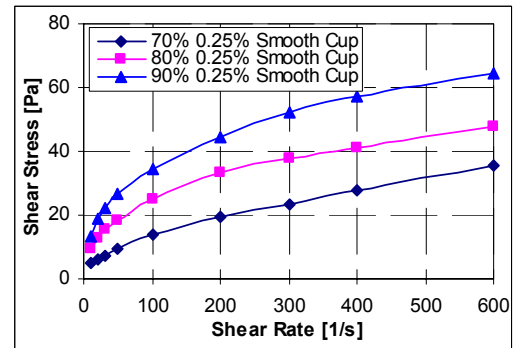

Fig. 6 Polymer foam (0.25%) rheology measured using smooth cup-rotor assembly

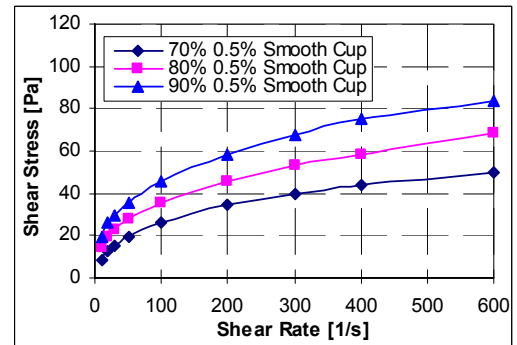

Fig. 7 Polymer foam (0.5%) rheology measured using smooth cup-rotor assembly

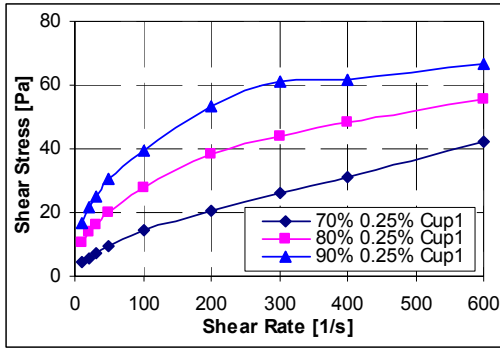

Fig. 8 Polymer foam (0.25%) rheology measured using less roughened cup-rotor assembly # 1

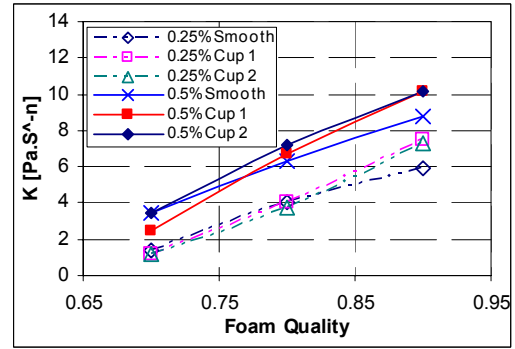

Fig. 12 Flow consistency index versus foam quality, polymer concentrations and cup-rotor assemblies

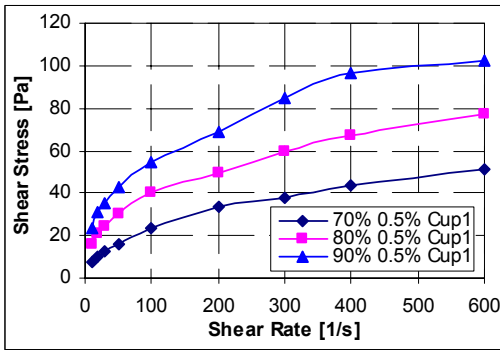

Fig. 9 Polymer foam (0.5%) rheology measured using less roughened cup-rotor assembly # 1

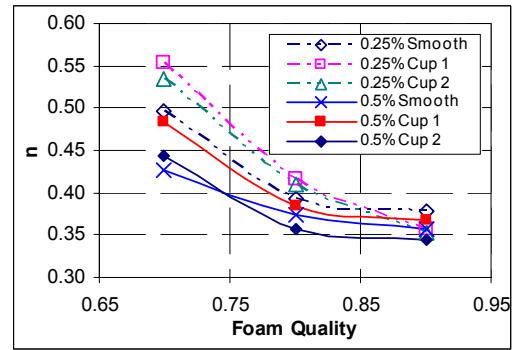

Fig. 13 Flow behavior index versus foam quality, polymer concentrations and cup-rotor assemblies

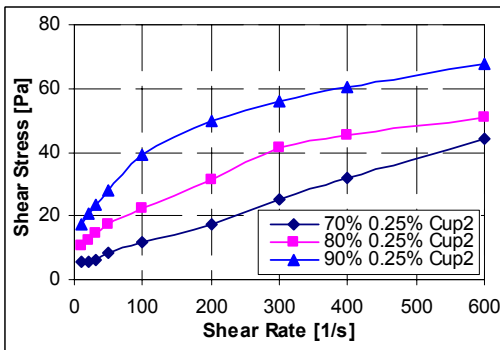

Fig. 10 Polymer foam (0.25%) rheology measured using more roughened cup-rotor assembly #2

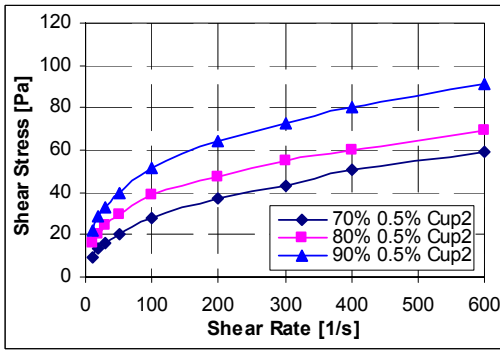

Fig. 11 Polymer foam (0.5%) rheology measured using more roughened cup-rotor assembly #2